

電菱
'18.11.09
開発課

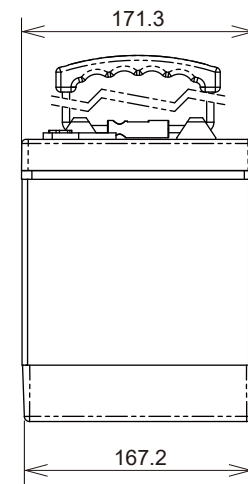
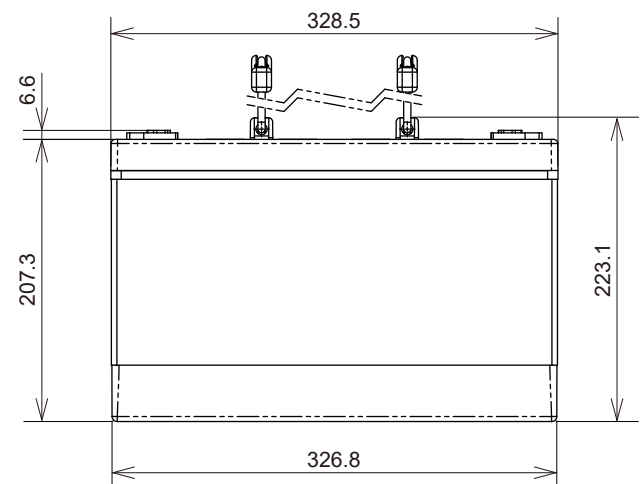
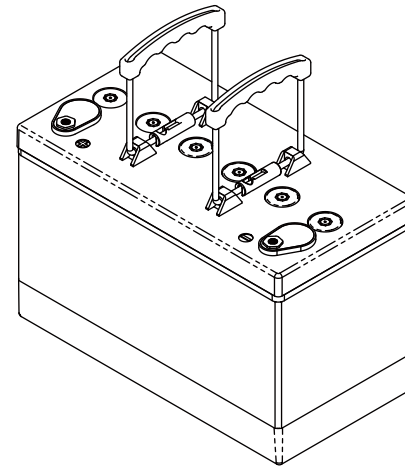
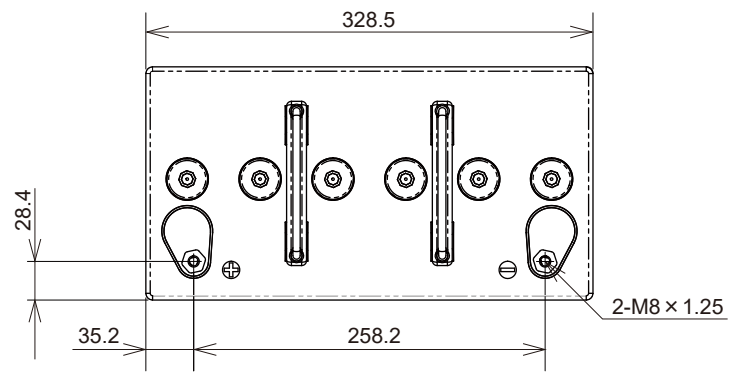

UNIT(単位) : mm

SCALE (尺度) 1:2.5	NAME (名称) DEEP CYCLE BATTERY
TOLERANCE (公差) ±1.5mm	
DATE (作成日) 2018.11.09	TYPE (型式) PVX-1080T
株式会社 電菱	DWG.NO. (図番) DC-P-008